

UNLESS OTHERWISE SPECIFIED		JRC WEB ACCESSORIES	
ALL DIAMETERS TO BE CONCENTRIC WITHIN 0.003		46 PASSAIC AVENUE FAIRFIELD, NJ 07004	
REMOVE ALL BURRS & SHARP EDGES		125 ✓	TITLE
		ASSEMBLY OF M-1386 - MD3" DIA. x 7" WW JRC AIR SHAFT (WEBTRON 650 / 750 UNWIND)	
CUSTOMER	DIMENSION	TOLERANCE ±	SIZE DATE
FINISH VARIOUS	FRACTIONAL	1/64	DWG NO
MATERIAL	ANGULAR	0.5°	B
	X.XX	0.010	REV
	X.XXX	0.005	B-4378
REFERENCE DRAWING	X.XXXX	0.0005	SCALE
			DRAWN
			SHEET 1 OF 4

4

3

2

1

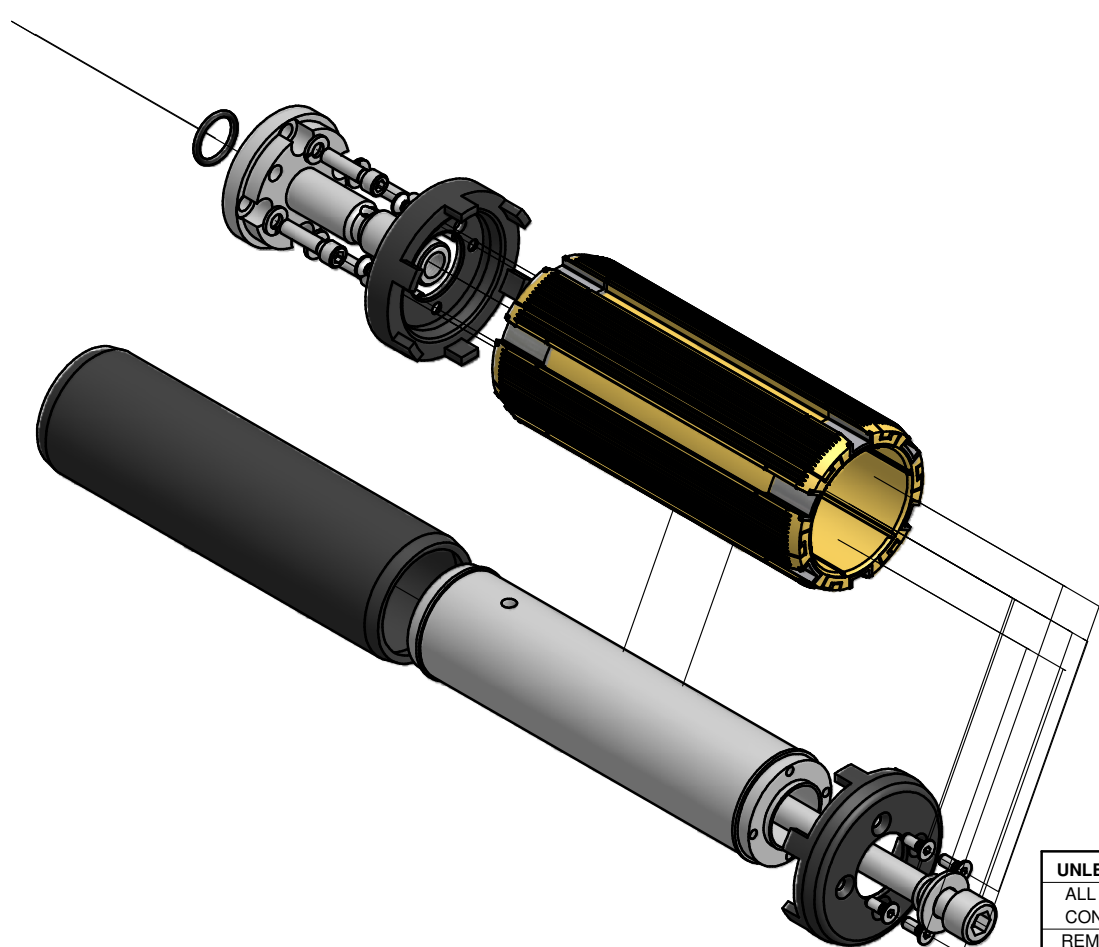

Parts List			
ITEM	QTY	PART NUMBER	DESCRIPTION
1	1	A-1307	APAPTER - UNWIND
2	1	B-4351	BODY
3	1	B-4349	CAP - CLAMP - TORQU E RING
4	1	B-4350	CAP - CLAMP - TORQU E RING
5	1	ANSI B18.3 - 1/2-20 - 5	Hexagon Socket Head C ap Screw
6	1	B-4377	WASHER
7	1	B-4034	O - RING
8	2	B-4035	O - RING
9	6	B-4375	HD LEAF
10	12	A-1899	INSERT
11	1	B-4376	BLADDER
12	8	ANSI B18.3 - No. 10 - 32 - 1/2	Hexagon Socket Flat Co untersunk Head Cap Scr ew
13	4	ASME B18.21.1 - 1/4 Re gular. Carbon Steel	Helical Spring Lock Was her
14	4	ANSI B18.3 - 1/4 - 20 - 1	Hexagon Socket Head C ap Screw

UNLESS OTHERWISE SPECIFIED
 ALL DIAMETERS TO BE
 CONCENTRIC WITHIN 0.003
 REMOVE ALL BURRS
 & SHARP EDGES

JRC WEB ACCESSORIES
 46 PASSAIC AVENUE FAIRFIELD, NJ 07004

TITLE
**ASSEMBLY OF M-1386 - MD3" DIA. x 7"
 WW JRC AIR SHAFT (WEBTRON 650 /
 750 UNWIND)**

CUSTOMER	DIMENSION	TOLERANCE ±
FINISH VARIOUS	FRACTIONAL	1/64
MATERIAL	ANGULAR	0.5°
	X.XX	0.010
	X.XXX	0.005
REFERENCE DRAWING	X.XXXX	0.0005

SIZE	DATE	DWG NO	REV
B		B-4378	
SCALE	DRAWN	SHEET 2 OF 4	

4

3

2

1

4 | 3 | 2 | 1

B

B

A

A

A

A

4 | 3 | 2 | 1

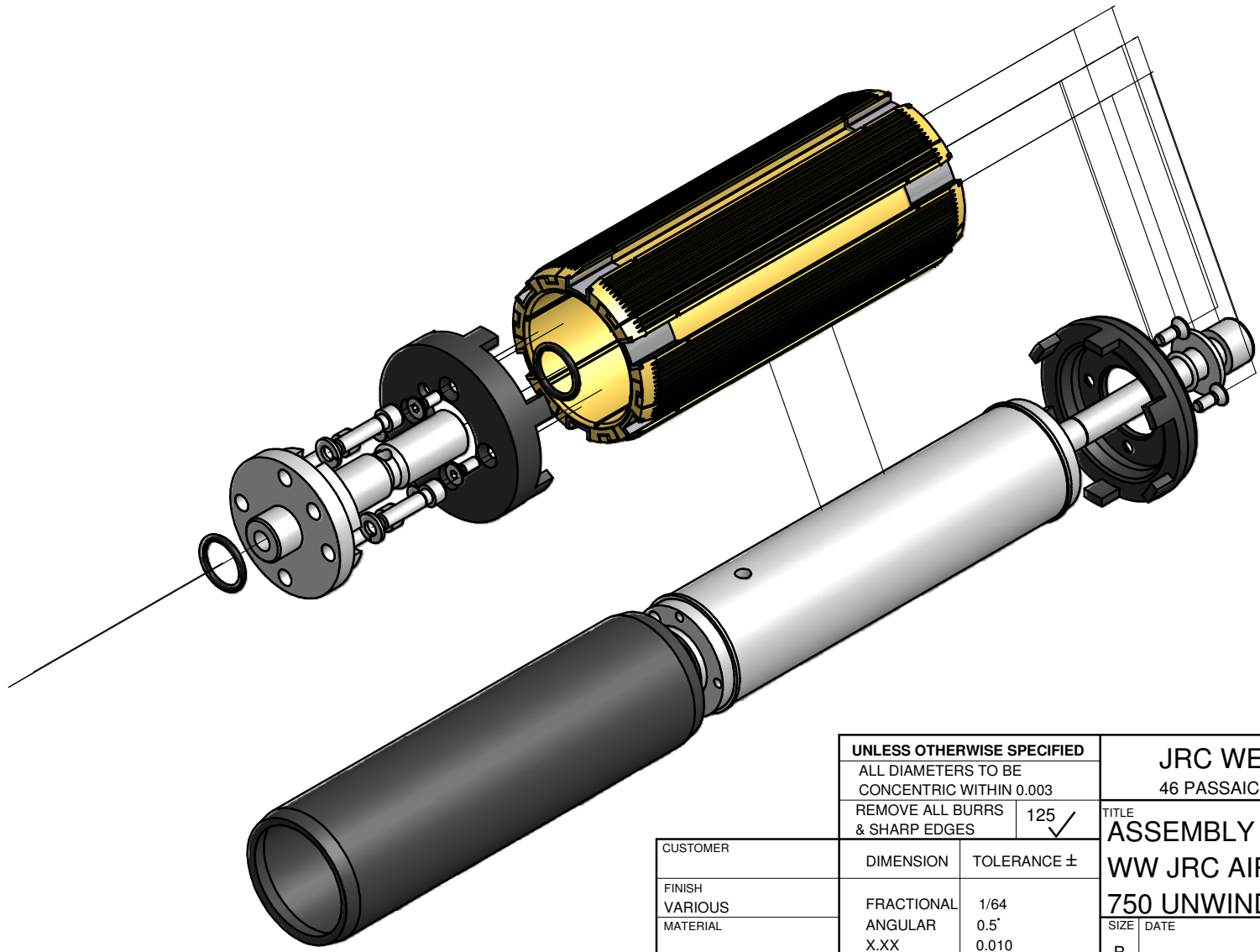

UNLESS OTHERWISE SPECIFIED
 ALL DIAMETERS TO BE
 CONCENTRIC WITHIN 0.003
 REMOVE ALL BURRS
 & SHARP EDGES

JRC WEB ACCESSORIES
 46 PASSAIC AVENUE FAIRFIELD, NJ 07004

TITLE
**ASSEMBLY OF M-1386 - MD3" DIA. x 7"
 WW JRC AIR SHAFT (WEBTRON 650 /
 750 UNWIND)**

CUSTOMER	DIMENSION	TOLERANCE ±
FINISH	FRACTIONAL	1/64
VARIOUS	ANGULAR	0.5°
MATERIAL	X.XX	0.010
	X.XXX	0.005
REFERENCE DRAWING	X.XXXX	0.0005

125 ✓

SIZE	DATE	DWG NO	REV
B		B-4378	

SCALE DRAWN SHEET 3 OF 4

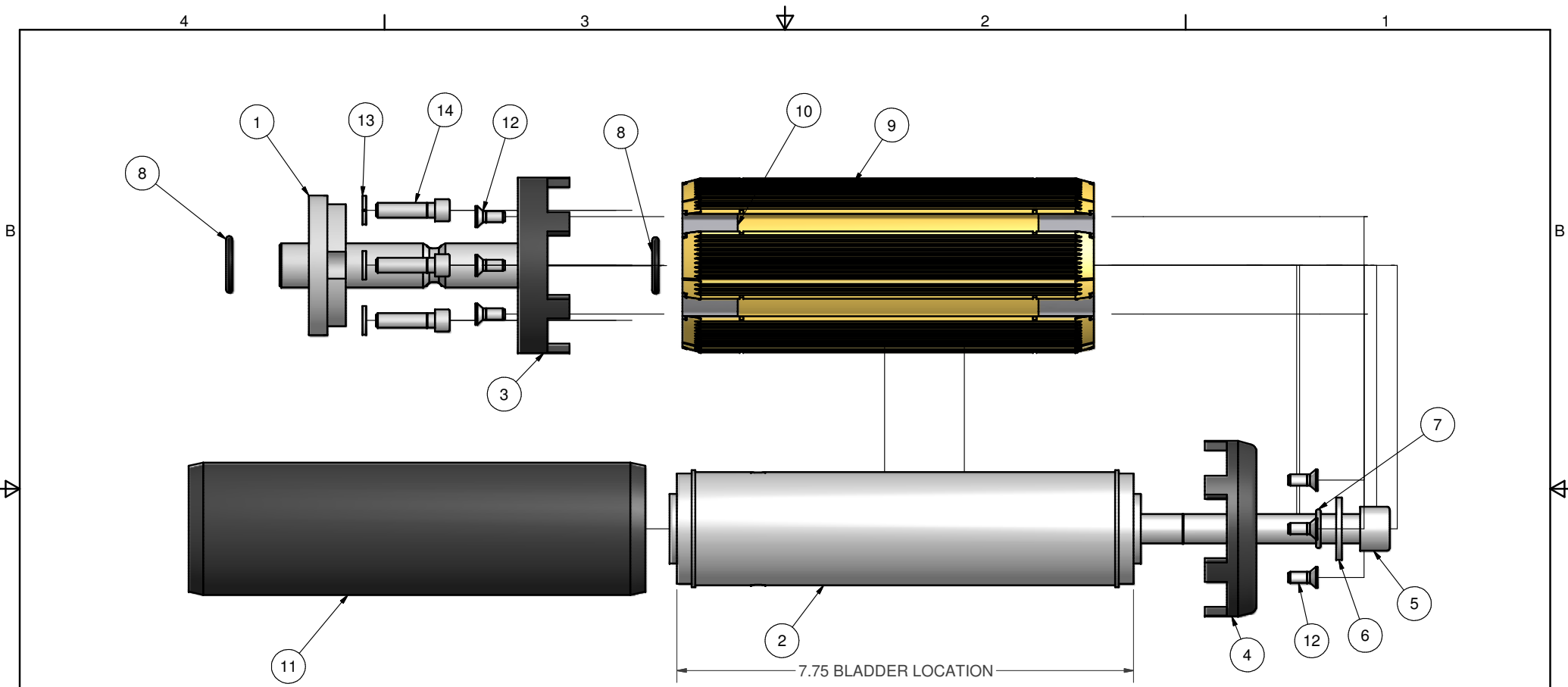

UNLESS OTHERWISE SPECIFIED
 ALL DIAMETERS TO BE
 CONCENTRIC WITHIN 0.003
 REMOVE ALL BURRS
 & SHARP EDGES

JRC WEB ACCESSORIES
 46 PASSAIC AVENUE FAIRFIELD, NJ 07004

TITLE
**ASSEMBLY OF M-1386 - MD3" DIA. x 7"
 WW JRC AIR SHAFT (WEBTRON 650 /
 750 UNWIND)**

CUSTOMER	DIMENSION	TOLERANCE ±
FINISH	FRACTIONAL	1/64
VARIOUS	ANGULAR	0.5°
MATERIAL	X.XX	0.010
	X.XXX	0.005
REFERENCE DRAWING	X.XXXX	0.0005

SIZE	DATE	DWG NO	REV
B		B-4378	
SCALE	DRAWN	SHEET 4	OF 4