

The DBM is an economic hydraulic caliper brake, which offer variety of thrusters and features.

Stable performance and dissipating heat of the disc brakes which withstand frequent uses.

These brakes do not require an adjustment while they are in use, and their repairs are simple.

While their braking forces may be arbitrarily adjusted, the range of braking force is widened.

These brakes are resistant to dust and wetting, and withstand high ambient temperatures.

Only for brake fluid not for mineral oil.



LEFT TYPE

Size		DBM 10	DBM 20
Sizes of cylinders		2 1/8"	2 1/8"
Area of cylinders		22.88 cm ²	22.88 cm ²
Amount of operating Oil		About 2.5cc	About 2.5cc
Operating oil pressures	Normal working	50 kg/cm ²	50 kg/cm ²
	Maximum	70 kg/cm ²	70 kg/cm ²
Disc thickness		10 mm	20 mm
Disc O. D. mm		200↑	200↑
Unit Weight		5 kg	5.5 kg

DBM brake separate into left and right type, which depends on position of oil- inlet. Please indicate left or right side type when order.

● Torque versus Pressure

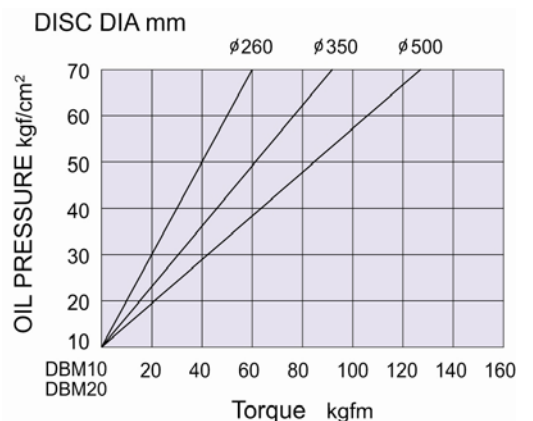

DIMENSION

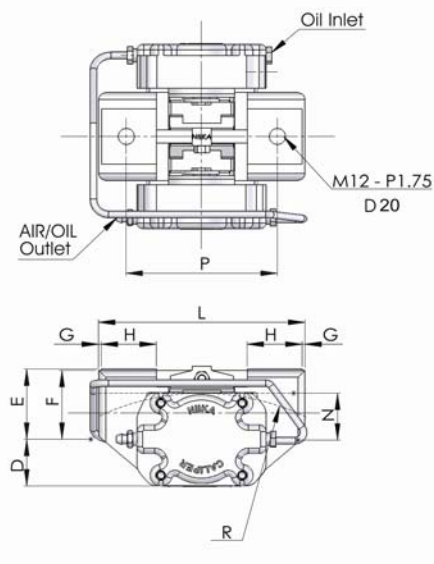

RIGHT TYPE

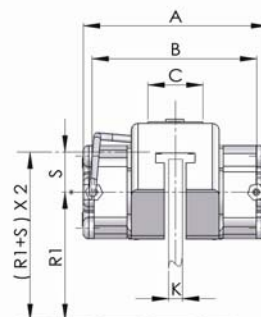

Size	A	B	C	D	E	F	G	H	K	L	N	P	R	S
DBM 10	135	118	40	34	51	50	2	40	10	150	34	110	350	30
DBM 20	145	128	50	34	51	50	2	40	20	150	34	110		30

Warning : The initial torque on new units can be 30% to 50% less then the catalogue value until the friction facing and friction disc are lapped or worn in.

NIIKA Limited reserves the right to modify or change the design without prior notice.