

## E/P CONVERTER

Input adjustment for 0~10V / 0~20mA / 0~100mA

First of all, connect power supply AC 220V to contacts 1, 2 of JP2

(I) Adjustment of zero point:

Measure pin 6 of U1 by the probe (+) of electric meter, and measure the heat outlet of 7812 by the probe (-). Then adjust R43 to  $\pm 0.1\text{VDC}$ , and then adjust R46 to  $\pm 0.001\text{VDC}$ .

(II) Adjustment of sensitivity: (factory setting  $0.025\text{VD} = 0.03\text{kg/cm}^2$ )

Measure the test hole of sensitivity by the probe (+) of electric meter, and adjust R12 to  $0.01 \sim 0.1\text{VDC}$ .

(III) Adjustment of SPAN:

Input +10VDC to pin 5 and 6 of JP4. Connect air pressure input, which should be larger than or equal to  $\text{kg/cm}^2$ . Then adjust RG to let air pressure output maintain as  $6 \text{ kg/cm}^2$ .

Input adjustment for 4~20mA

Steps (I) and (II) same as above.

(III) Adjust input voltage to 4VDC, and output pressure to  $6 \text{ kg/cm}^2$ .

(IV) Zero point shift to  $-10\text{VDC}$ , measure pin 1 of U9 by the probe (+) of electric meter, and adjust R46 and R43 to  $-1\text{VDC}$ .

## Wiring of E/P CONVERTER:

Point A : Test point of sensitivity

R12 : Adjustment of sensitivity

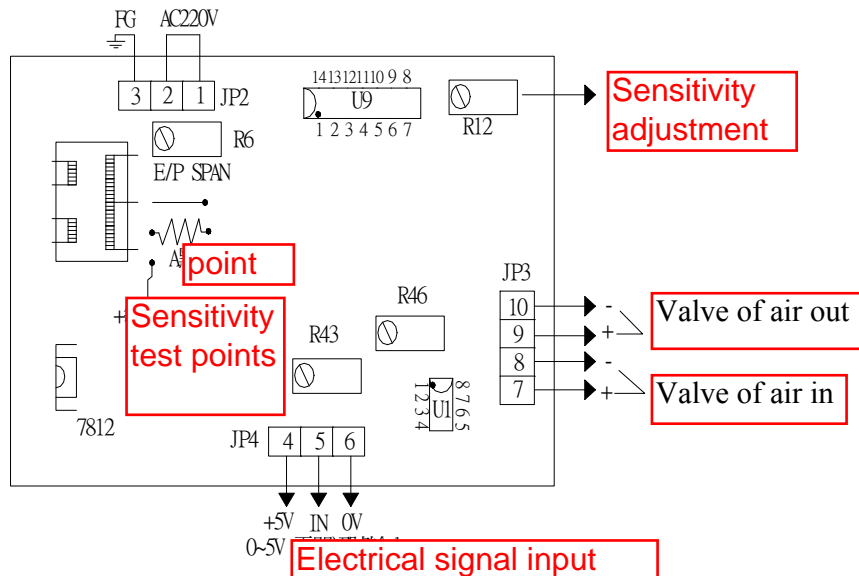

JP4 4,5,6 0~5V power signal input JP3 9,10 Valve of air out

JP3 7,8 Valve of air in