

DBM 20 Pneumatic / Hydraulic Caliper

The DBM is an economic hydraulic caliper brake, which offer variety of thrusters and features.

Stable performance and dissipating heat of the disc brakes which withstand frequent uses.

These brakes do not require an adjustment while they are in use, and their repairs are simple.

While their braking forces may be arbitrarily adjusted, the range of braking force is widened.

These brakes are resistant to dust and wetting, and withstand high ambient temperatures.

Only for brake fluid not for mineral oil.



LEFT TYPE

Size	DBM 20	
Sizes of cylinders	2 1/8"	
Area of cylinders	3.55 in ² 22.88 cm ²	
Amount of operating Oil	About 0.15 in ³ [About 2.5cc]	
Operating oil pressures	Normal working	711.17 psi [50 kg/cm ²]
	Maximum	995.63 psi [70 kg/cm ²]
Disc thickness inches	0.79 [20 mm]	
Disc O. D. inches	7.87 [200 mm]	
Unit Weight lb	11.02 [5.5 kg]	

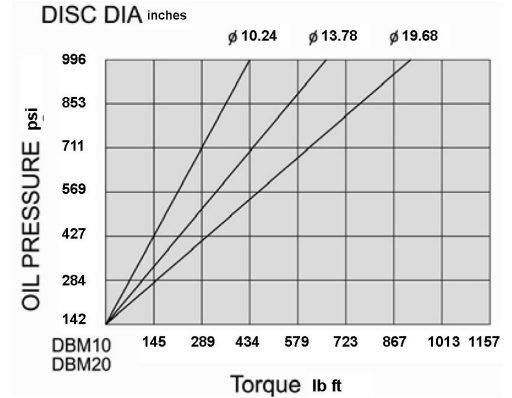

DIMENSION

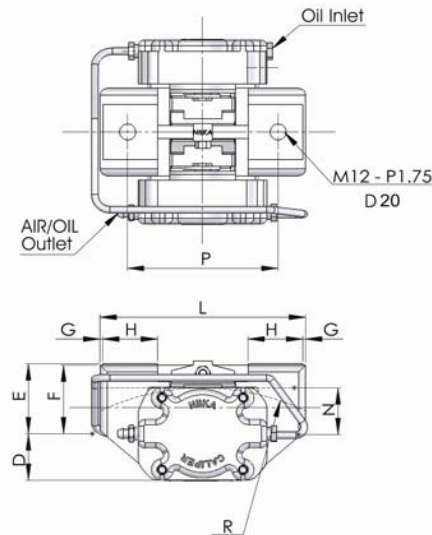

RIGHT TYPE

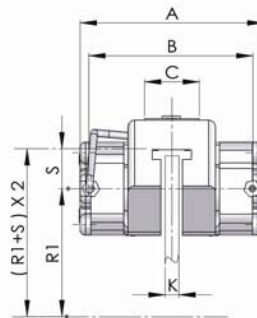

Warning : The initial torque on new units can be 30% to 50% less than the catalogue value until the friction facing and friction disc are lapped or worn in.

Size	A	B	C	D	E	F	G	H	K	L	N	P	R	S
DBM 20 [mm]	5.71 [145]	5.04 [128]	1.97 [50]	1.34 [34]	2.01 [51]	1.97 [50]	0.08 [2]	1.57 [40]	0.79 [20]	5.90 [150]	1.34 [34]	4.33 [110]	13.8 [350]	1.18 [30]

disc are lapped or worn in.