

REV.	DATE	BY	DESCRIPTION

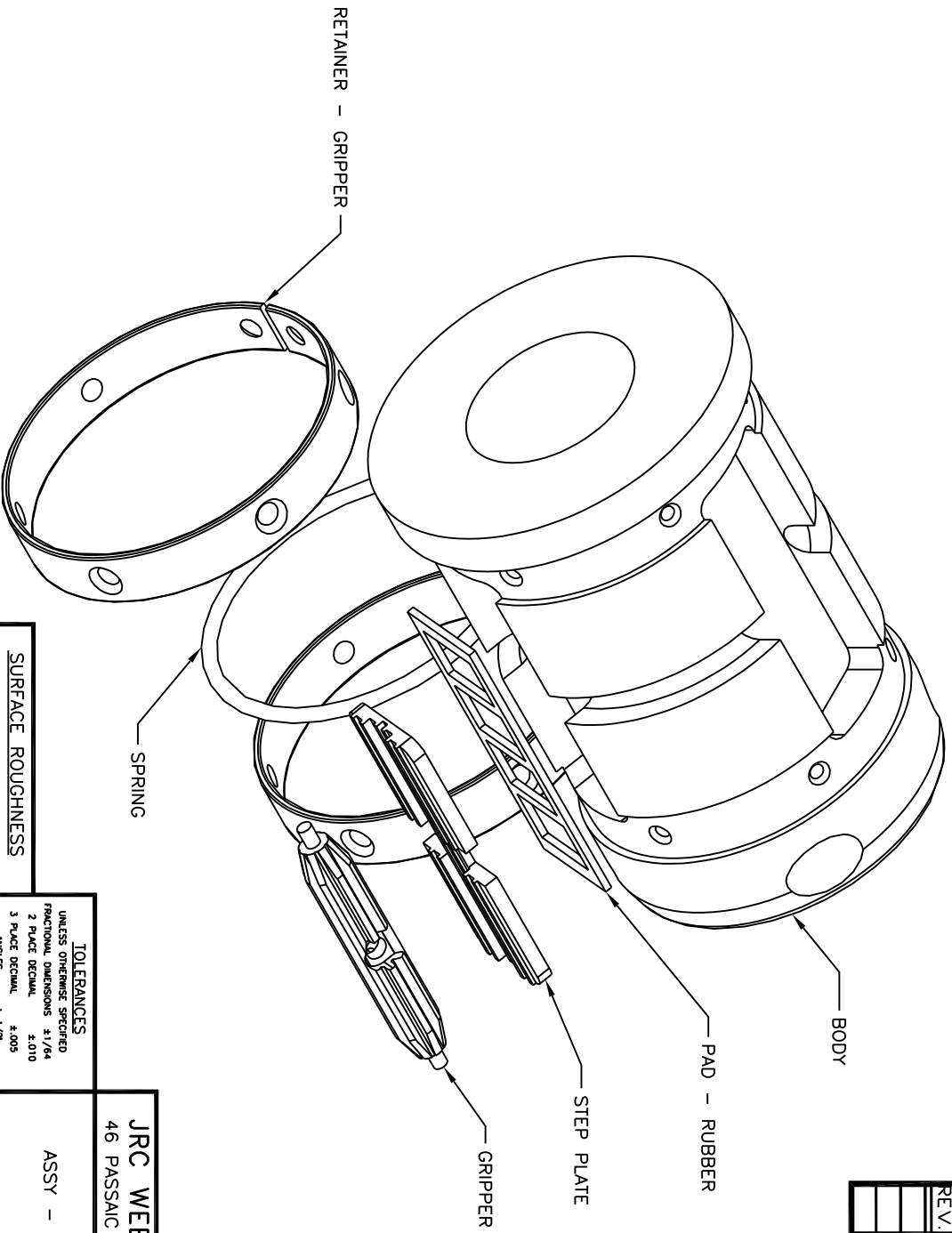

REF. DRWG:

SURFACE ROUGHNESS
 UNLESS OTHERWISE SPECIFIED ALL MACHINED SURFACES TO BE 125 MICRONS.
 REMOVE ALL BURNS & SHARP CORNERS

TOLERANCES
 UNLESS OTHERWISE SPECIFIED
 FRACTIONAL DIMENSIONS ±1/64
 2 PLACE DECIMAL ±.010
 3 PLACE DECIMAL ±.005
 ANGLES ± 1/2°
NOTES
 1. TO BE CONCENTRIC WITHIN PROBLET
 2. WITHIN PROBLET

JRC WEB ACCESSORIES, INC.
 46 PASSAIC AVENUE, FAIRFIELD, NJ 07004

ASSY - MECHANICAL CHUCK

DRAWN	SCALE	DRAWING NO.	REV.
		B-3173	
DATE			